

Fall                  Spring                  Fall                  Spring                  Fall                  Spring                  Fall                  Spring

A passing score on the Mathematics Placement Test administered by the University or a grade of C or better in MATH 120.

C or better in CHEM 103 or placement at Math Level II. Corequisite: MATH 102/119, placement at Math Level III or higher or permission of instructor.

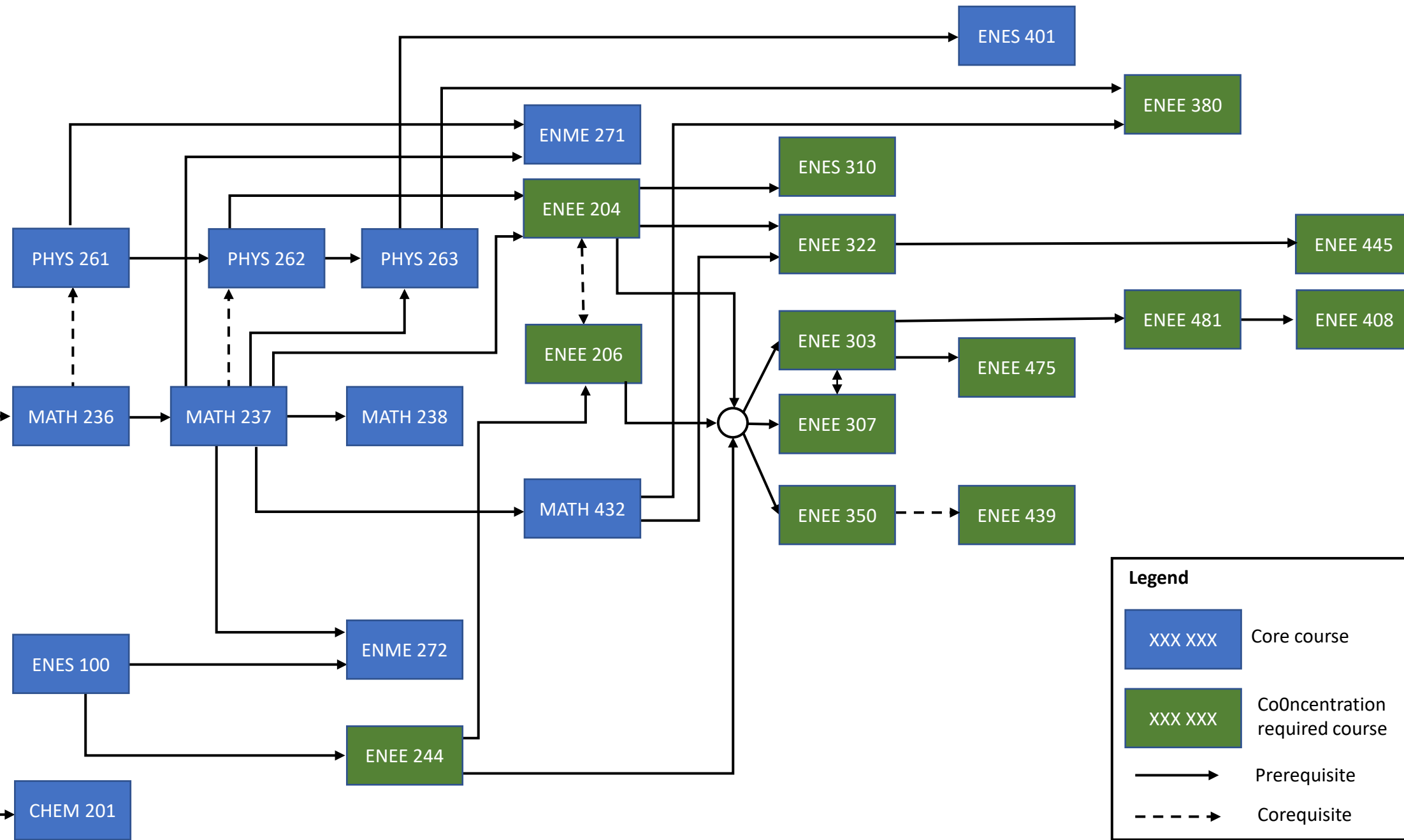

**Legend**

- XXX XXX Core course
- XXX XXX CoOncentration required course
- Prerequisite
- Corequisite

Core	Requirements
CHEM 201 General Chemistry I	Prerequisite: C or better in CHEM 103 or placement at Math Level II. Corequisite: MATH 102/119, placement at Math Level III or higher or permission of instructor. GEP Group C.
ENES 100 Introduction to Engineering Design	
ENES 401 Fundamentals of Energy Engineering	Prerequisite: Physics 263
ENME 271 Numerical Methods in Mechanical Engineering	Prerequisites: PHYS 261, MATH 237.
ENME 272 Introduction to Computer-Aided Design	Prerequisites: ENES 100 and a "C" or better in Math 237.
MATH 236 Calculus I	Prerequisite: A passing score on the Mathematics Placement Test administered by the University or a grade of C or better in MATH 120. MAY BE USED TO FULFILL CORE SKILL 3.
MATH 237 Calculus II	Prerequisite: a grade of C or better in MATH 236
MATH 238 Calculus III	Prerequisite: a grade of C or better in MATH 237.
MATH 432 Differential Equations	Prerequisite: a grade of C or better in MATH 237.
PHYS 261 Principles of Physics I – Mechanics	Corequisite: MATH 236.
PHYS 262 Principles of Physics II – Thermodynamics, Electricity and Magnetism	Prerequisite: PHYS 261. Corequisite: MATH 237
PHYS 263 Principles of Physics III – Light and Modern Physics	Prerequisites: PHYS 262 and MATH 237
Electrical Engineering courses	
ENEE 204 Basic Circuit Theory	Prerequisites: PHYS 262 and MATH 237
ENEE 206 Fund. Digital and Electric Circuits Lab	Prerequisite: ENEE 244. Corequisite: ENEE 204
ENEE 244 Digital Logic Design	Prerequisite: ENES 100
ENEE 303 Analog and Digital Electronics	Prerequisites: "C" or better in ENEE 204, 206 and 244. Corequisite: ENEE 307 or permission of department chair
ENEE 307 Electronic Circuits Lab	Prerequisites: "C" or better in ENEE 204, 206 and 244. Corequisite: ENEE 303 or permission of the department chair
ENEE 322 Signal and System Theory	Prerequisites: ENEE 204 and MATH 432
ENEE 350 Computer Organization	Prerequisites: "C" or better in ENEE 204, 206 and 244.

ENEE 380 Electromagnetic Theory	Prerequisites: PHYS263 and junior standing. Corequisite(s) MATH 432.
ENEE 445 Introduction to Communication Systems	Prerequisite: ENEE 322
ENEE 408 Capstone Design Project for Electrical Engineers	Prerequisites: ENEE 481 and permission of department chair. May not be taken at the same time as ENME 410 and PHYS 492
ENEE 439 Topics in Signal Processing	Co-requisite: ENEE 350
ENEE 475 Power Electronics	Prerequisite: "C" or better in ENEE 303 or ENME 350
ENEE 481 Project Development in Electrical Engineering	Prerequisites: ENEE 303 and completion of all ENEE 100- and 200-level courses with a "C" or better. May not be taken at the same time as PHYS 491
ENES 310 Mechatronic and Robotic Design	Prerequisite: ENME 350 or ENEE 204